



Model Number

NRB50-FP-A2-P3-V1

Features

- 50 mm flush
- Reduction factor = 1

Accessories

V1-G

Female connector, M12, 4-pin, field attachable

V1-W

Female connector, M12, 4-pin, field attachable

V1-G-2M-PUR

Female cordset, M12, 4-pin, PUR cable

V1-W-2M-PUR

Female cordset, M12, 4-pin, PUR cable

Technical Data

General specifications

Switching element function		PNP	NO/NC
Rated operating distance	s_n	50 mm	
Installation		flush	
Output polarity		DC	
Assured operating distance	s_a	0 ... 40.5 mm	
Reduction factor r_{Al}		1	
Reduction factor r_{Cu}		1	
Reduction factor r_{304}		1	
Reduction factor r_{S37}		1	

Nominal ratings

Operating voltage	U_B	10 ... 30 V DC
Switching frequency	f	0 ... 80 Hz
Hysteresis	H	typ. 3 %
Reverse polarity protection		reverse polarity protected
Short-circuit protection		pulsing
Voltage drop	U_d	≤ 3 V
Rated insulation voltage	U_{BIS}	50 V
Operating current	I_L	0 ... 200 mA
Off-state current	I_r	0 ... 0.5 mA typ. 0.1 μ A at 25 °C
No-load supply current	I_0	≤ 20 mA
Time delay before availability	t_v	≤ 300 ms
Operating voltage indicator		LED, green
Switching state indicator		LED, yellow

Functional safety related parameters

MTTF _d	854 a
Mission Time (T _M)	20 a
Diagnostic Coverage (DC)	0 %

Ambient conditions

Ambient temperature	0 ... 50 °C (32 ... 122 °F) (± 10 % changing operating distance) -25 ... 70 °C (-13 ... 158 °F) (± 20 % changing operating distance)
---------------------	---

Mechanical specifications

Connection type	Connector M12 x 1, 4-pin
Housing material	PBT/metal
Sensing face	PBT
Housing base	PBT
Degree of protection	IP68

Compliance with standards and directives

Standard conformity	
Standards	EN 60947-5-2:2007 IEC 60947-5-2:2007

Approvals and certificates

UL approval	cULus Listed, General Purpose
CSA approval	cCSAus Listed, General Purpose
CCC approval	CCC approval / marking not required for products rated ≤ 36 V

Dimensions

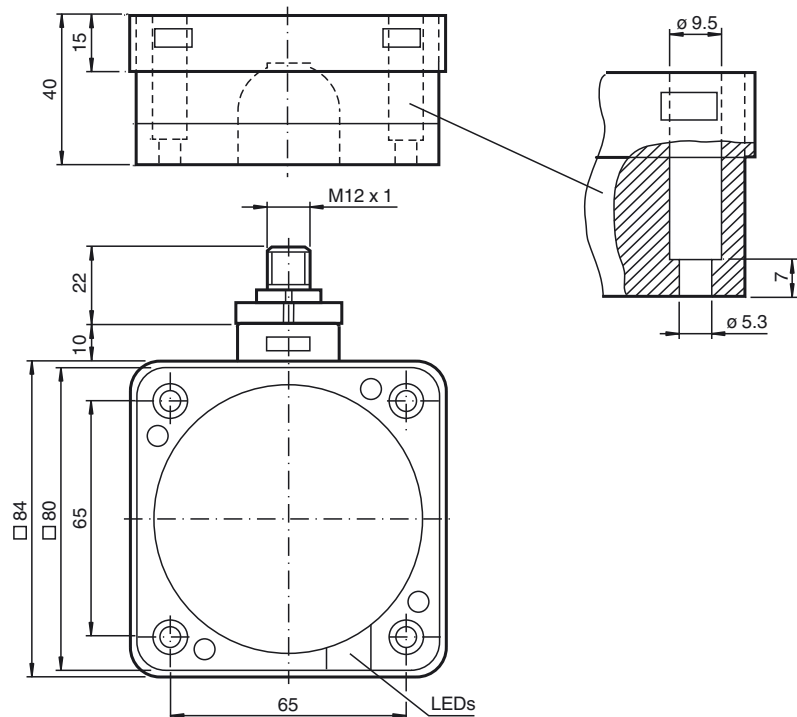

Electrical Connection

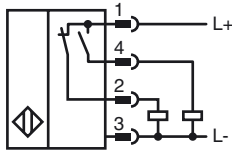

Pinout

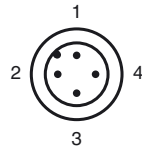

Wire colors in accordance with EN 60947-5-2

1	BN	(brown)
2	WH	(white)
3	BU	(blue)
4	BK	(black)

Installation Hint

These sensors are particularly suitable for embedded installation in floor conveyor systems. The installation of the switch in a metal base plate provides it with considerable protection against mechanical damage.

Care should be taken to ensure that the cut out in the base plate is at least 104 mm x 104 mm and that the sensor is positioned centrally within this cut out.

The active surface of the sensor must not be recessed with respect to the front face of the base plate.

The high switching distance guarantees safe detection and thus control of the floor conveyor system.

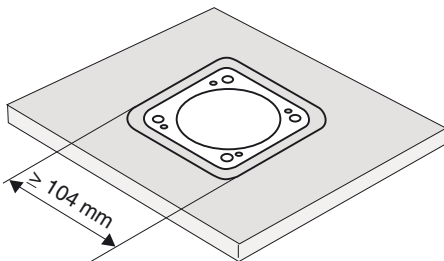

Caution!
After removal of the metal screen the proximity switch can no longer be mounted as an embedded installation.